

## Type DB-H Hydraulic Dirt Bucket

The type DB-H Hydraulic Dirt Bucket is a slip-on attachment allowing quick connection to a Forklift.

The hydraulic operation allows for full backwards tilt making the bucket suitable for liquid products. This bucket has been manufactured with a hardened steel wear edge.

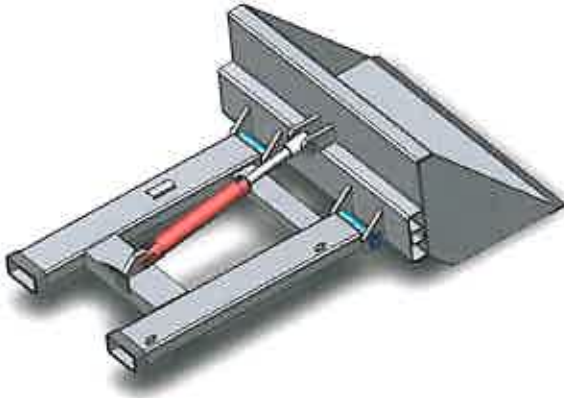

### SPECIFICATIONS:

- Pocket size 165 x 65mm
- Pocket Centres 635mm
- Bucket Width 1200mm
- Safe Working Load 500kg
- Unit Weight 200kg
- Volume Capacity 0.22 cu m

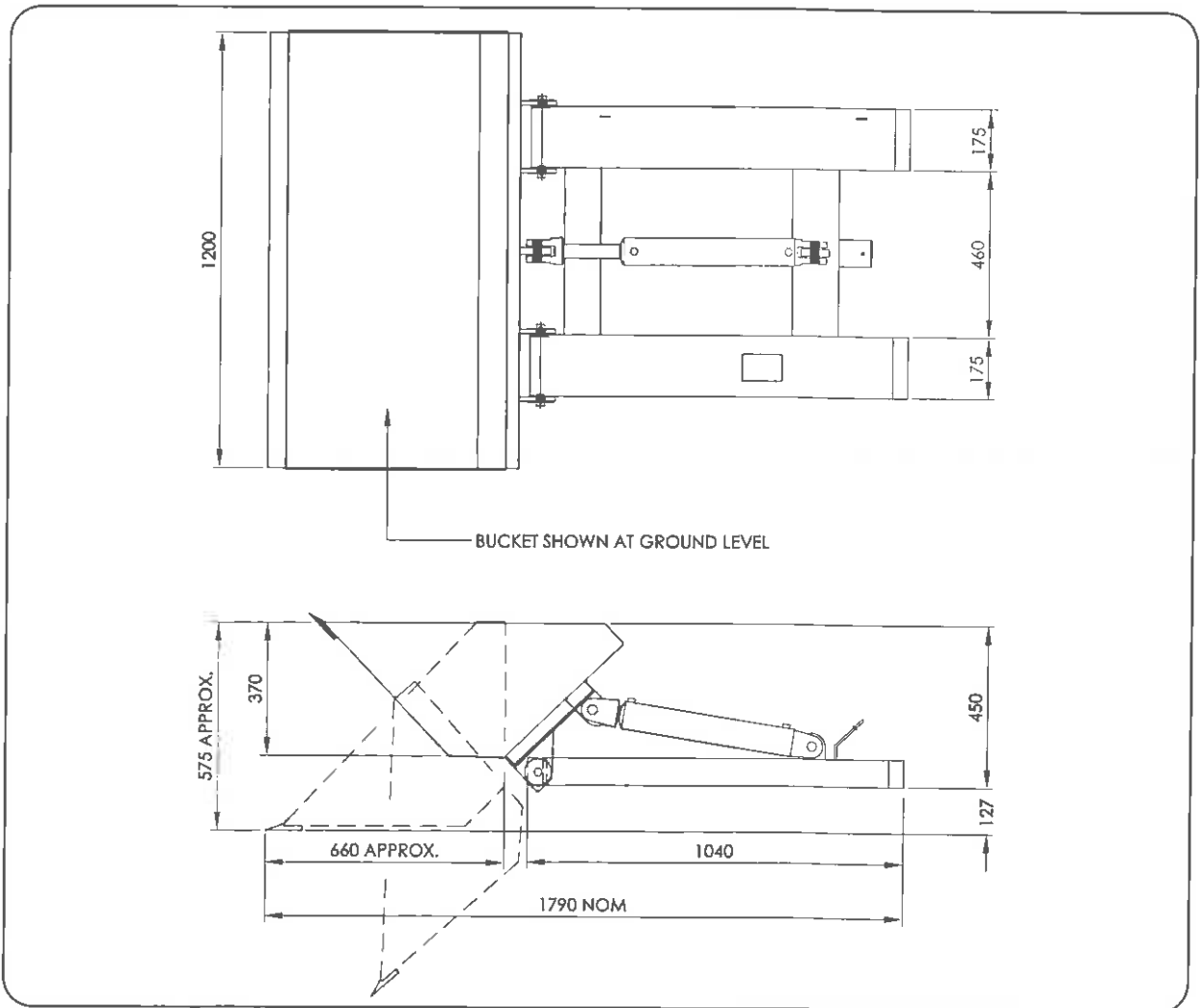



Product Search:

go >

[home](#)

[about us](#)

[products](#)

[product videos](#)

[worldwide distributors](#)

[contact us](#)

Hydraulic Forklift Attachments

[< Back to Product Menu](#)

[Grab Attachments](#)

[180 Degree Carriage Rotator](#)

[Push Off Attachment](#)

[Hydraulic Extension Reachforks](#)

[Drum Handling & Rotating](#)

[Dirt Buckets - Hydraulic](#)

**Dirt Buckets - Hydraulic:**

**Type: DB-H Hydraulic Dirt Bucket**

Type DB-H slip-on Dirt Buckets allow for quick connection to the lift truck. The hydraulic operation allows for full backwards lift making this bucket suitable for liquid products. The Unit is fitted with a hardened wear edge. Available in either painted or galvanised finish

**SPECIFICATIONS:**

- \* Volume Capacity: 0.22 cu m
- \* Safe Working Load: 500kg
- \* Bucket Width: 1200mm
- \* Fork Pocket Size: 165 x 65mm
- \* Fork Pocket Centres: 635mm
- \* Unit Weight: 200kg

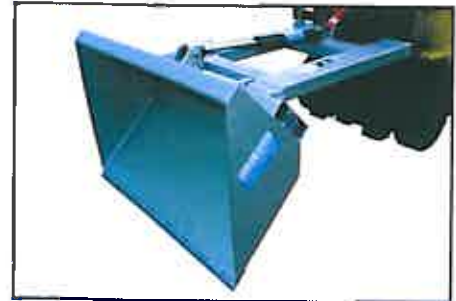

**Drawing and Specifications:** [DB\\_H\\_Sales](#)

[Send Enquiry](#)

[Tell a friend](#)

[View Gallery](#)

[Print Page](#)

[Back to Top](#)

**Type: DBHS2-12 / DBHS2-18 Hydraulic Dirt Bucket**

Type DBHS2 Hydraulic Dirt Bucket is a slip-on attachment allowing quick connection to the Forklift with the use of "Quick Connect" hydraulic couplings. The hydraulic operation allows for full backwards tilt making the bucket suitable for liquid products. These buckets are able to be used as tip-up bins for waste handling or for excavation and transport of loose material.

The bucket is manufactured with a hardened steel wear edge. Available in either enamel paint finish or galvanised.

**SPECIFICATIONS:**

- \* Safe Working Load: 1000kg
- \* Fork Pocket Size: 185 x 65mm
- \* Fork Pocket Centres: 750mm

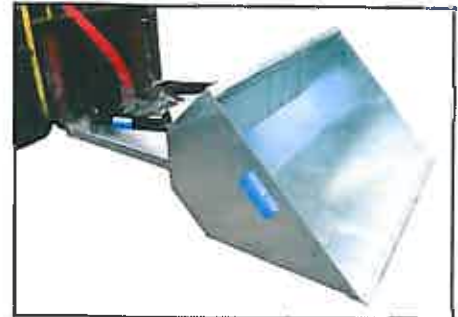
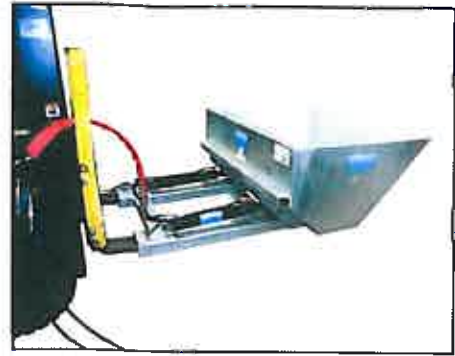

Type	Volume Capacity (cu. m)	Bucket Width (mm)	Unit Weight (kg)
DBHS2-12	0.50	1200	315
DBHS2-18	0.90	1800	390

Drawing and Specifications:  DBHS2\_Sales



[back to top >>](#)